

## 3.5 Ton 2-Post Lift



**Strong, Safe, Durable**

**The basic building block for your workshop**

**EELRKS703**

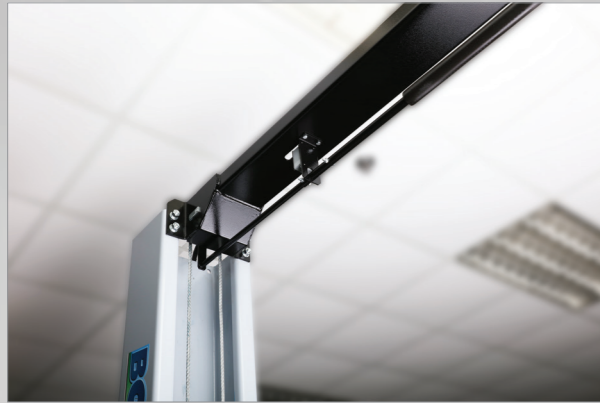

**Dual function overhead shut-off**

Lifting automatically shuts off at full height, regardless if vehicle touches the safety shut-off bar. This protects taller vehicles from being damaged and also protects the lift from over-pressure damages

**Single point manual lock release**

Lifting and lowering operation out of harms way



**Power packs configurations to suit your requirements**

Available in:

- 1) 3PH, 380V, 50 Hz
- 2) 1PH, 220V, 50/60 Hz

**Model Boxer EELRKS703**

**Clear floor design**

Provides unobstructed floor space. Ideal for under car servicing/major component replacement jobs



**Dual direct-drive hydraulic cylinders**

Ensures smooth operation with maximum lifting force

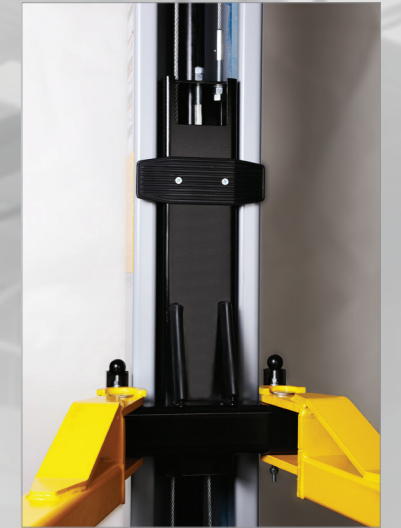

**Door protectors (Optional)**

Protect vehicle doors when getting in/out of vehicle



**Arm restraint**

The supporting arms are automatically locked in position/unlocked during the lifting operation/completely lowered. Designed to be safe and long lasting.



**Symmetrical arm design (2-stage)**

Allows bi-direction drive in operation, suitable for most workshop layout



## Specifications

|                        |   |
|------------------------|---|
| Type of lift           | Symmetrical                                 |
| Capacity               | 3500 kg                                     |
| Overall width          | 3402 mm                                     |
| Width between columns  | 2790 mm                                     |
| Drive-thru width       | 2554 mm                                     |
| Overall height         | 3596 mm                                     |
| Under bar clearance    | 3384 mm                                     |
| Pad height from floor  | 109 and 141 mm                              |
| Arm retracted length   | 781 mm                                      |
| Arm extended length    | 1142 mm                                     |
| Maximum lifting height | 1806 mm                                     |
| Lift time / Lower time | 50 / 45 sec                                 |
| Power supply           | 380VAC, 3PH, 50 Hz<br>220VAC, 1PH, 50/60 Hz |

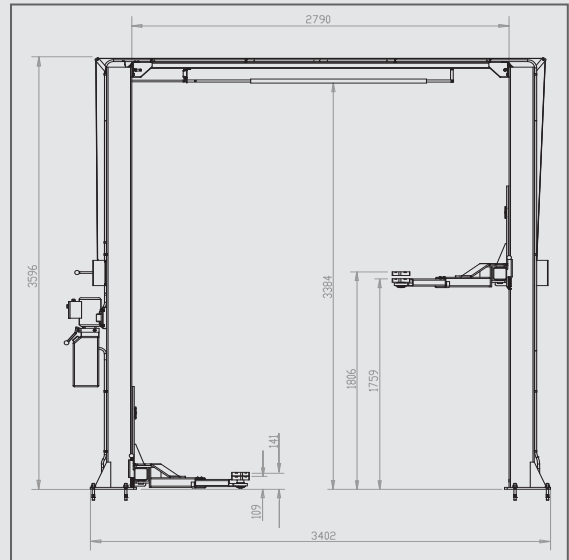

## Optional Accessories

### Height Extension Adaptors



#SEAM0090T84A 50 mm  
#SEAM0090T83A 100 mm

### Door Protectors



#SEL2P-11-00 (2 screws included)  
#S1-03589A (rubber pad only)



#S9-0241

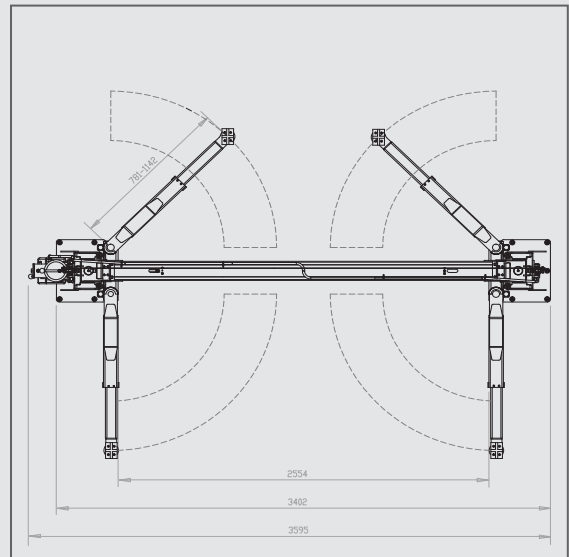

### SINGAPORE

Snap-on Tools Singapore Pte Ltd  
25 Tagore Lane, #01-02, Singapore 787602  
Tel: (65) 6451-5570 • Fax: (65) 6451-5574

### HONG KONG

Snap-on Tools Hong Kong Limited  
Unit 2010, 20/F, Laford Centre, 838 Lai Chi Kok Road,  
Cheung Sha Wan, Kowloon, Hong Kong  
Tel: (852) 2370-3700 • Fax: (852) 2370-3400

### INDONESIA

Snap-on Tools Singapore Pte Ltd - Indonesia Rep. Office  
Graha Pratama Building, 14th Floor, Jl. M.T. Haryono Kav 15,  
Jakarta 12810, Indonesia  
Tel: (62-21) 8370-9611 • Fax: (62-21) 8370-9612

### KOREA

Snap-on Tools Korea  
#505 & 506, BuCheon Techno Park Block 3, Building 301,  
365 SamJung-Dong, OhJung-Gu  
Bucheon City, GyeongGi-do, Korea 421-809  
Tel: (82-32) 326-7310 • Fax: (82-32) 326-7312

### MALAYSIA

Snap-on Tools Singapore Pte Ltd - Malaysia Branch  
B-6-10, Street Mall, One South, Taman Serdang Perdana,  
43300 Seri Kembangan, Selangor, Malaysia  
Tel: (603) 8957-1938 • Fax: (603) 8957-2938

### PHILIPPINES

Snap-on Tools Singapore Pte Ltd - Philippines Branch  
Unit 801 Prime Land, Market St., Madrigal Business Park,  
Ayala Alabang, Muntinlupa City,  
1781 Philippines  
Tel: (63-2) 843-7935 • Fax: (63-2) 843-7730

### TAIWAN

Snap-on Tools Singapore Pte Ltd - Taiwan Branch  
3F-4, #9 Wuquan 1st Road, New Taipei Ind. Park, Xinzhuang District 24892,  
New Taipei City, Taiwan ROC  
Tel: (886-2) 2298-9789 • Fax: (886-2) 2298-2288

### THAILAND

Snap-on Tools (Thailand) Co. Ltd.  
Talomsim Building, 924 Rama 3 Road, Bangpongpang Yannawa,  
Bangkok 10120, Thailand  
Tel: (66) 2294-9660 • Fax: (66) 2294-9665